



Convertible Freezer / Refrigerator

FKCH17F7H W

Frost Free 17 Cu. Ft.



Product Dimensions

Height (Including Hinges)	65-7/8"
Width	32"
Depth (Including Door)	26-5/8"

More Easy-To-Use Features

- Color-Coordinated Handle
- Reversible Door Swing Option
- 3 Full-Width Fixed Glass Shelves
- 2 Clear Crispers w/ Humidity Controls
- Gallon Door Storage
- Clear Dairy Door

ENERGY STAR®



Available in:



White
(W)

Signature Features

Convertible Freezer to Refrigerator

Select the option to use as an all freezer or all refrigerator when it's best for your needs.

Store-More™ Adjustable Door Bins

Flexible storage options, with door bins designed to reposition with ease to fit your needs.

Frost Free Operation

Never defrost your freezer again.

Bright Lighting

Our bright lighting makes it easy to see what's inside Internal Heater

Features	
Door Handle Design	Reach-Through
Reversible Door	Yes
Automatic Door Closer	Yes
Leveling Legs	Yes
Defrost	Frost Free
Adjustable Temperature Control	Yes
Interior Lighting	Bright
Full-Width Fixed Shelves	3 Glass
Store-More™ Adjustable Door Bins	4 Clear
Convertible	Yes
Certifications	
ENERGY STAR®	Yes
CSA Rating	Household
Specifications	
Total Capacity (Cu. Ft.)	16.7
Shelf Area (Sq. Ft.)	17.6
Annual Energy (kWH)	615
Annual Energy Cost (.1065/kWH)	\$65
Power Supply Connection Location	Lower Right Rear
Voltage Rating	115V
Connected Load (kW rating) @ 115 Volts ¹	.58
Amps @ 115 Volts	5
Minimum Circuit Required (Amps)	15
Shipping Weight (Approx.)	208 Lbs.

¹An electrical supply with grounded three-prong receptacle is required. The power supply circuit must be installed in accordance with current edition of National Electrical Code (NFPA 70) and local codes & ordinances.

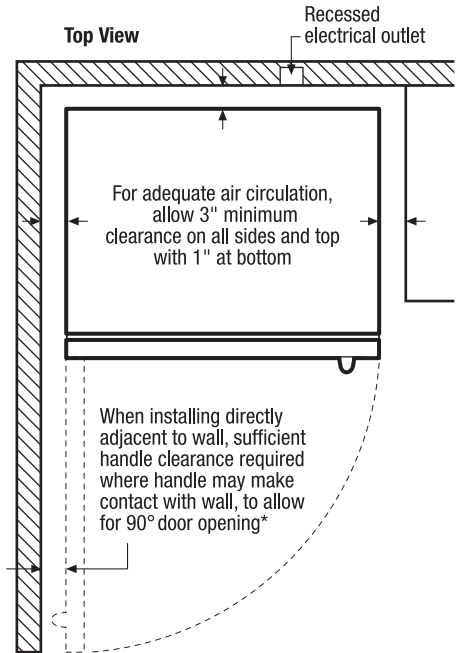
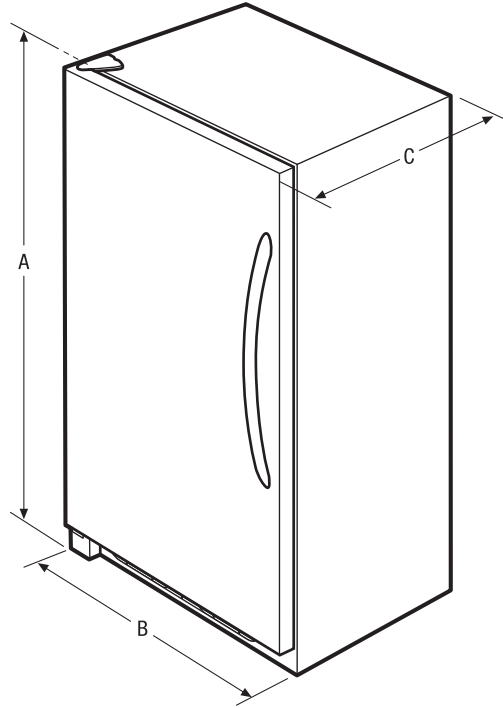

* When installing freezer adjacent to wall, cabinet or other appliance that extends beyond front edge of unit, 20" minimum clearance recommended to allow for optimum 140° door swing, providing complete basket access and removal. (Absolute 3" minimum clearance will ONLY allow for 90° door swing which will provide limited basket access with restricted removal.)

NOTE: For planning purposes only. Always consult local and national electric and plumbing codes. Refer to Product Installation Guide for detailed installation instructions on the web at frigidaire.com.



Product Dimensions	
A - Height (Including Hinges)	65-7/8"
B - Width	32"
C - Depth (Including Door)	26-5/8"
D - Depth with Door Open 90°	57-1/2"

Accessories information available on the web at frigidaire.com

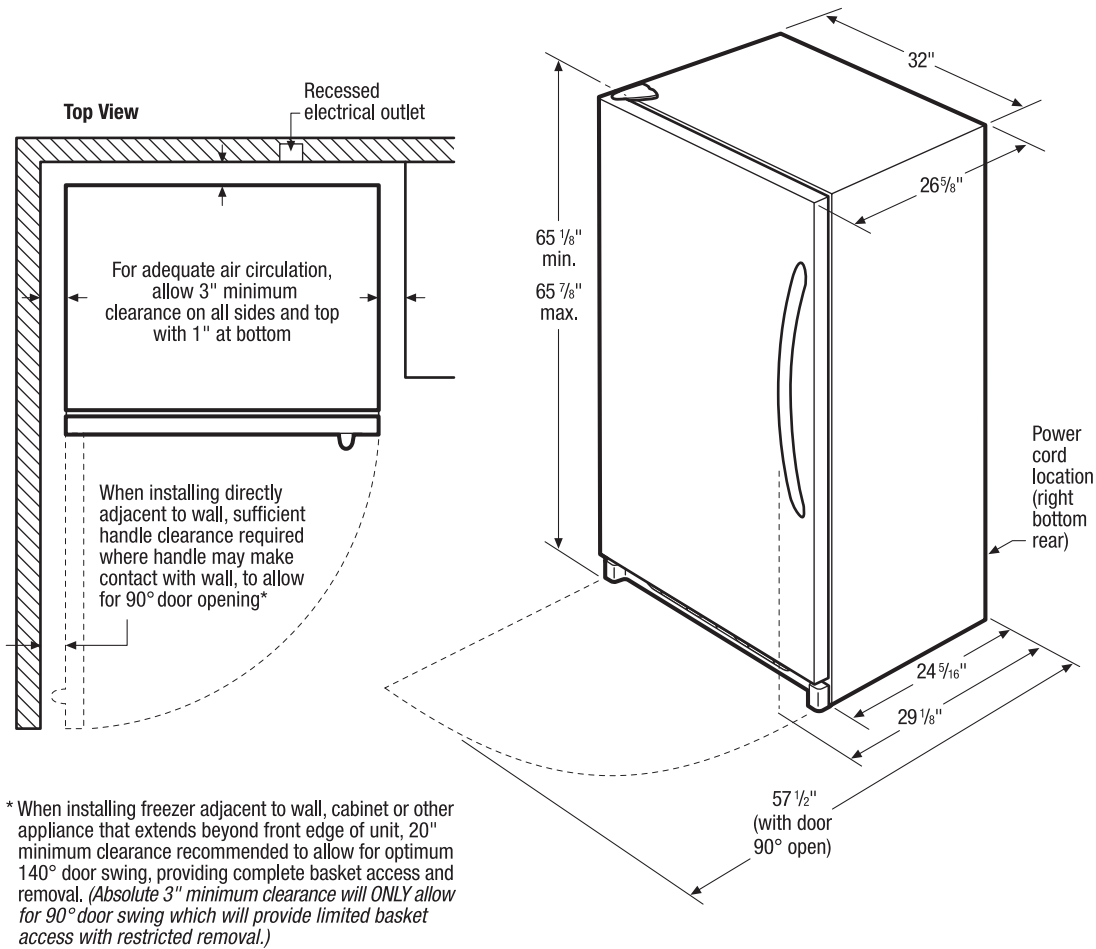

Convertible Freezer/Refrigerator Specifications

- Product Shipping Weight (approx.) - 208 Lbs.
- An electrical supply with grounded three-prong receptacle is required. The power supply circuit must be installed in accordance with current edition of *National Electrical Code (NFPA 70)* and local codes & ordinances.
- Voltage Rating - 115V
- Connected Load (kW Rating) @ 115 Volts = 0.58 kW
- Amps @ 115 Volts = 5 Amps
- Always consult local and national electric codes.
- For adequate air circulation, allow 3" minimum clearance on all sides and top with 1" at bottom.

- When installing freezer adjacent to wall, cabinet or other appliance that extends beyond front edge of unit, 20" minimum clearance recommended to allow for optimum 140° door swing, providing complete basket access and removal. (Absolute 3" minimum clearance will ONLY allow for 90° door swing which will provide limited basket access with restricted removal.)
- Locate where surrounding air temperature will not exceed 110° F, to ensure optimum performance. (Temperatures 32° F and below will NOT affect operation.)
- All bottom corners of unit MUST rest firmly on solid level surface of hard material, same height as flooring. Surface must be strong and stable enough to support unit when fully loaded.
- Equipped with adjustable leveling legs to ensure unit is level, which is required in order to function properly.

Note: For planning purposes only. Refer to Product Installation Guide on the web at frigidaire.com for detailed instructions.