

# Freezer

FFU21F5H W

**Frost Free**  
**21 Cu. Ft. Upright**



### Product Dimensions

Height (Including Hinges)	71-1/4"
Width	32"
Depth (Including Door)	31-1/8"

### More Easy-To-Use Features

#### Lock with Pop-Out Key

The freezer key automatically ejects after locking the door so you won't leave it in the door.

#### Power-On Indicator Light

Know at a glance that your freezer is working.

#### Bright Lighting

Our bright lighting makes it easy to see what's inside.

#### SpaceWise™ Shelf Bookends

Clever and flexible bookends are designed to hold more frozen food containers upright.

#### Color-Coordinated Handle

#### 6 Fixed Door Racks

#### 2 Full-Width Fixed Wire Shelves

#### 1 Full-Width Slide-Out Storage Basket

Available in:



White  
(W)

## Signature Features

### Ready-Select™ Controls with Upfront Display

Easily select options with the touch of a button.

### Store-More™ Capacity

Our large capacity freezer gives you room to store more.

### Automatic Alerts

Freezer alerts you if the door is left open or if the temperature rises.

### Frost Free Operation

Never defrost your freezer again.

Features	
Door Handle Design	Reach-Through
Reversible Door	
Automatic Door Closer	Yes
Leveling Legs	Yes
Lock with Pop-Out Key	Yes
Defrost	Frost Free
Adjustable Temperature Control	Ready-Select™
Front Digital Display	Yes
Temp Display Mode	1-7
High-Temp Duration Readout	
High-Temp Alarm	Yes
Door Ajar Alarm	Yes
Airflow Ports	1
Enhanced Interior Lighting	Bright
Interior Light	Yes
Full-Width Adjustable Shelves	2 Wire
Full-Width Fixed Shelves	2 Wire
Removable Trivet	
SpaceWise™ Shelf Bookend	3
Mid-Level Baskets	
Lower Storage Basket	1
Basket Dividers	
Retractable Pizza Shelf	
Soft Freeze Zone	
Store-More™ Adjustable Door Bins	
Full-Width Door Bins	
Store-More™ Tilt-Out Wire Door Bins	
Fixed Door Racks	6
Defrost Drain	
Power-On Light	Yes
Convertible	
Certifications	
CSA Rating	Household
Specifications	
Total Capacity (Cu. Ft.)	20.5
Shelf Area (Sq. Ft.)	19.69
Annual Energy (kWH)	766
Annual Energy Cost (.1065/kWH)	\$82
Power Supply Connection Location	Lower Right Rear
Voltage Rating	115V
Connected Load (kW rating) @ 115 Volts <sup>1</sup>	.58
Amps @ 115 Volts	5
Minimum Circuit Required (Amps)	15
Shipping Weight (Approx.)	258 Lbs.

<sup>1</sup>An electrical supply with grounded three-prong receptacle is required. The power supply circuit must be installed in accordance with current edition of National Electrical Code (NFPA 70) and local codes & ordinances.

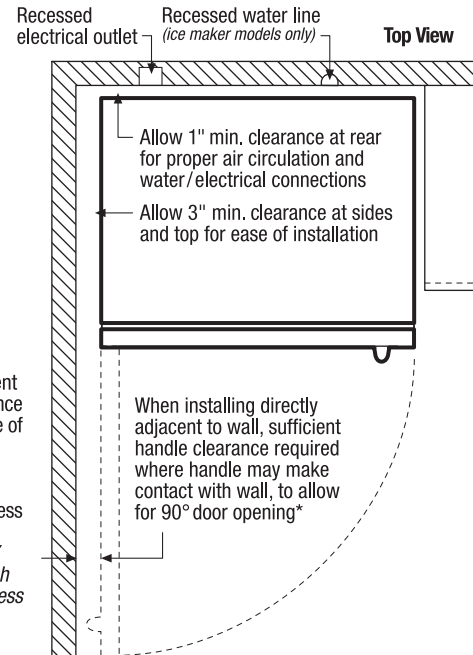
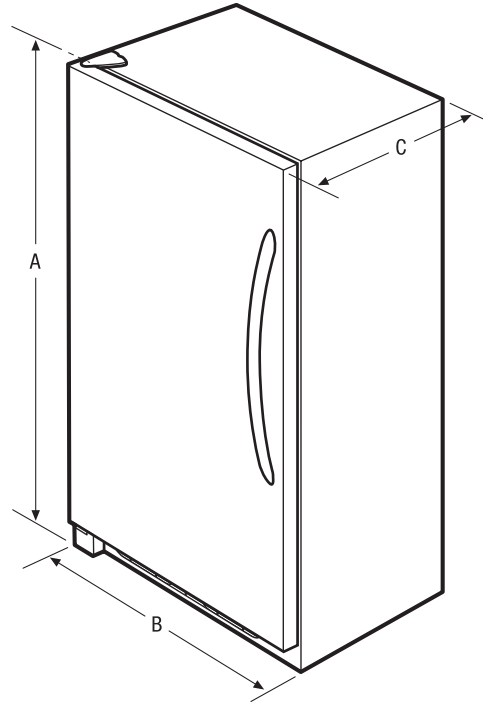

\* When installing freezer adjacent to wall, cabinet or other appliance that extends beyond front edge of unit, 20" minimum clearance recommended to allow for optimum 140° door swing, providing complete basket access and removal. (Absolute 3" minimum clearance will ONLY allow for 90° door swing which will provide limited basket access with restricted removal.)

NOTE: Always consult local and national electric codes. Refer to Product Installation Guide for detailed installation instructions on the web at [frigidaire.com](http://frigidaire.com).



Product Dimensions	
A - Height (Including Hinges)	71-1/4"
B - Width	32"
C - Depth (Including Door)	31-1/8"
D - Depth with Door Open 90°	59-3/8"