

Freezer
FFU17M7H W

Manual Defrost
17 Cu. Ft. Upright



Product Dimensions

Height (Including Hinges)	65-3/4"
Width	32"
Depth (Including Door)	29-1/8"

More Easy-To-Use Features

Lock with Pop-Out Key

The freezer key automatically ejects after locking the door so you won't leave it in the door.

Power-On Indicator Light

Know at a glance that your freezer is working.

Bright Lighting

Our bright lighting makes it easy to see what's inside.

Defrost Water Drain

Use the drain to conveniently remove water during defrosting.

Color-Coordinated Handle

4 Adjustable Door Bins

3 Full-Width Fixed Wire Shelves

1 Full-Width Slide-Out Storage Basket

Available in:



White
(W)

Signature Features

SpaceWise™ Organizational System

Our total organizational system includes fixed wire shelves, lower level baskets and adjustable door storage.

Store-More™ Tilt-Out Wire Door Bins

Store more in the door — and get easy access with the tilt-out feature.

Store-More™ Adjustable Door Bins

Flexible storage options, with door bins designed to reposition with ease to fit your needs.

Soft Freeze Zone

A bin that remains slightly warmer than the freezer interior for convenient storage for soft freeze items such as ice cream.

Features	
Door Handle Design	Reach-Through
Reversible Door	
Automatic Door Closer	Yes
Leveling Legs	Yes
Lock with Pop-Out Key	Yes
Defrost	Manual
Adjustable Temperature Control	Mechanical Dial
Front Digital Display	
Temp Display Mode	1-7
High-Temp Duration Readout	
High-Temp Alarm	
Door Ajar Alarm	
Airflow Ports	
Enhanced Interior Lighting	Bright
Interior Light	Yes
Full-Width Adjustable Shelves	
Full-Width Fixed Shelves	3 Wire
Removable Trivet	
SpaceWise™ Shelf Bookend	
Mid-Level Baskets	
Lower Storage Basket	1
Basket Dividers	
Retractable Pizza Shelf	
Soft Freeze Zone	Yes
Store-More™ Adjustable Door Bins	4
Full-Width Door Bins	1
Store-More™ Tilt-Out Wire Door Bins	1
Fixed Door Racks	
Defrost Drain	Yes
Power-On Light	Yes
Convertible	
Certifications	
CSA Rating	Household
Specifications	
Total Capacity (Cu. Ft.)	17.0
Shelf Area (Sq. Ft.)	15.45
Annual Energy (kWH)	480
Annual Energy Cost (.1065/kWH)	\$51
Power Supply Connection Location	Lower Right Rear
Voltage Rating	115V
Connected Load (kW rating) @ 115 Volts ¹	.58
Amps @ 115 Volts	5
Minimum Circuit Required (Amps)	15
Shipping Weight (Approx.)	208 Lbs.

¹An electrical supply with grounded three-prong receptacle is required. The power supply circuit must be installed in accordance with current edition of National Electrical Code (NFPA 70) and local codes & ordinances.

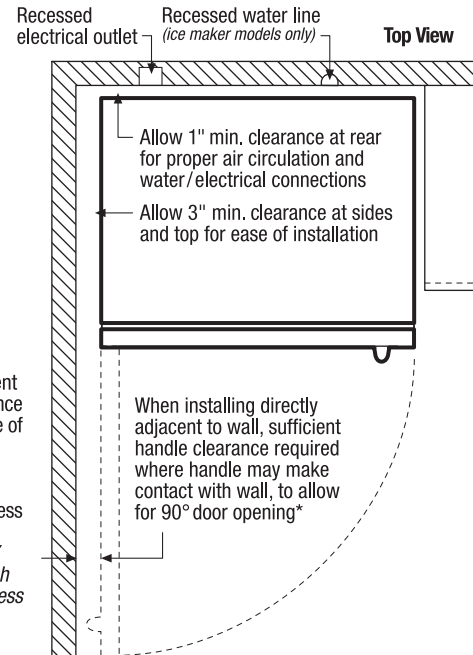
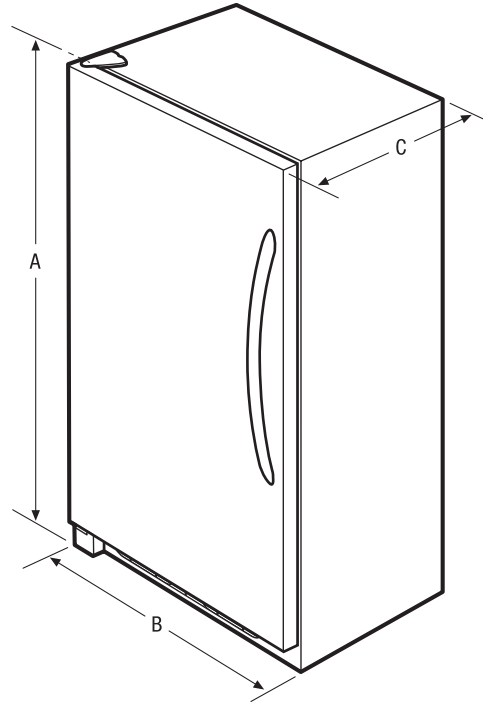

* When installing freezer adjacent to wall, cabinet or other appliance that extends beyond front edge of unit, 20" minimum clearance recommended to allow for optimum 140° door swing, providing complete basket access and removal. (Absolute 3" minimum clearance will ONLY allow for 90° door swing which will provide limited basket access with restricted removal.)

NOTE: Always consult local and national electric and plumbing codes. Refer to Product Installation Guide for detailed installation instructions on the web at frigidaire.com.



Product Dimensions	
A - Height (Including Hinges)	65-3/4"
B - Width	32"
C - Depth (Including Door)	29-1/8"
D - Depth with Door Open 90°	57-3/8"