



Home Comfort

FRA25EST2

Heavy-Duty Air Conditioner/Heater



Signature Features

Effortless™ Temperature Control

Our air conditioners maintain the preset room temperature, so you will remain comfortable at all times.

Remote Control

Allows you to precisely control the temperature and fan speed from across the room.

Ready-Select™ Controls

Easily select options with the touch of a button.

Effortless™ Clean Filter

Our anti-microbial filter cleans the air, removing harmful bacteria.

Product Dimensions

Height	18-5/8"
Width	26-1/2"
Depth	26-1/2"

More Easy-To-Use Features

Sleep Mode

Quiet operation keeps you cool without keeping you awake. Plus, Sleep Mode gradually increases room temperature after being activated.

Quickly Cools

Comfort Control Design

Easily control the direction of your cool air, wherever your unit is.

Effortless™ Restart

Automatically resumes operating at its previous settings when power is restored to your unit.

Supplemental Heat Only

Our versatile unit offers a supplemental heating capability, providing you with an additional heat source when needed.

Clean Filter Alert

Power Cord

Comes with an extra long three-prong cord that makes extension cords unnecessary.

SpaceWise™ Adjustable Design

Optional Side Panels extend so you can adjust your unit to fit your window.

24 Hour On/Off Timer

Performance	BTUs
Cool	25,000/24,700
Heat	16,000/13,000

Performance	
BTU (Cool)	25,000/24,700
BTU (Heat)	16,000/13,000
Dehumidification (Pints/Hour)	8.0
Cool Area (Sq. Ft.)	1,672
Energy Efficiency Ratio	9.4
Electrical	
Volts	240/208
Amps (Cool)	12.0/13.0
Amps (Heat)	22.5/20.0
Watts (Cool)	2,660/2,630
Watts (Heat)	4,900/4,000
Length of Power Cord (Min./Max.)	5'/6'
Plug Type (NEMA)*	LCDI (D)
Features	
Electronic Controls	Ready-Select™ Controls
Fan Speeds (Cool/Fan/Heat)	3/3/3
Low Voltage Start-Up	Yes
Auto Cool Function	Yes
Energy Save	Yes
Sleep Mode	Yes
Filter Check	Yes
24 Hour On/Off Timer	Yes
Clean Air Ionizer	
Remote Control	Full-Function with Heat
Air CFM (High/Med/Low)	523/482/438
Air Direction Control	Auger Multi-Direction
Fresh Air/Exhaust Vent/Closed	Yes/Yes/Yes
Filter Type	Antimicrobial Mesh
Filter Access	Tilt-Out
Slide-Out Chassis	Yes
Cabinet Louvers	Yes
Rear Grille	Yes
Window Mounting Kit (Included)	Pleated Quick Mount
Certifications	
Performance	AHAM
Specifications	
Refrigerant	R410a
Shipping Weight (Approx.)	141 Lbs.

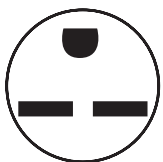
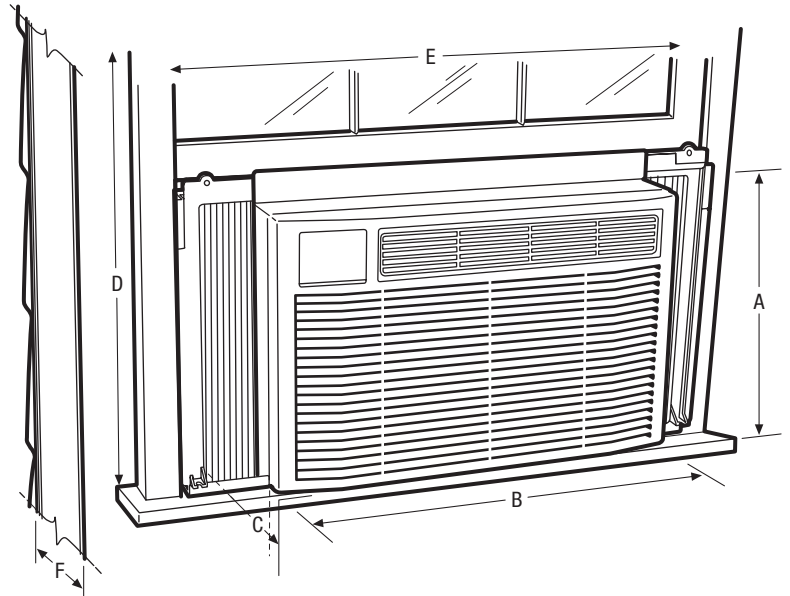

*Plug Type (NEMA)
(D) 6-30P

NOTE: For planning purposes only. Always consult local and national electric codes. Refer to Product Installation Guide for detailed installation instructions on the web at frigidaire.com.



Product Dimensions	
A - Height	18-5/8"
B - Width	26-1/2"
C - Depth	26-1/2"

Window Dimensions	
D - Height (Min.)	19-1/2"
E - Width (Min./Max.)	31" / 42"
Wall Cutout Dimensions	
F - Max. Wall Thickness	10"
Height	18-5/16"
Width	26-3/4"

Accessories information available on the web at frigidaire.com